

**Note:** Follow the disassembly procedure in the numerical order given.

## 2-2. ORNAMENT HINGE ASSY

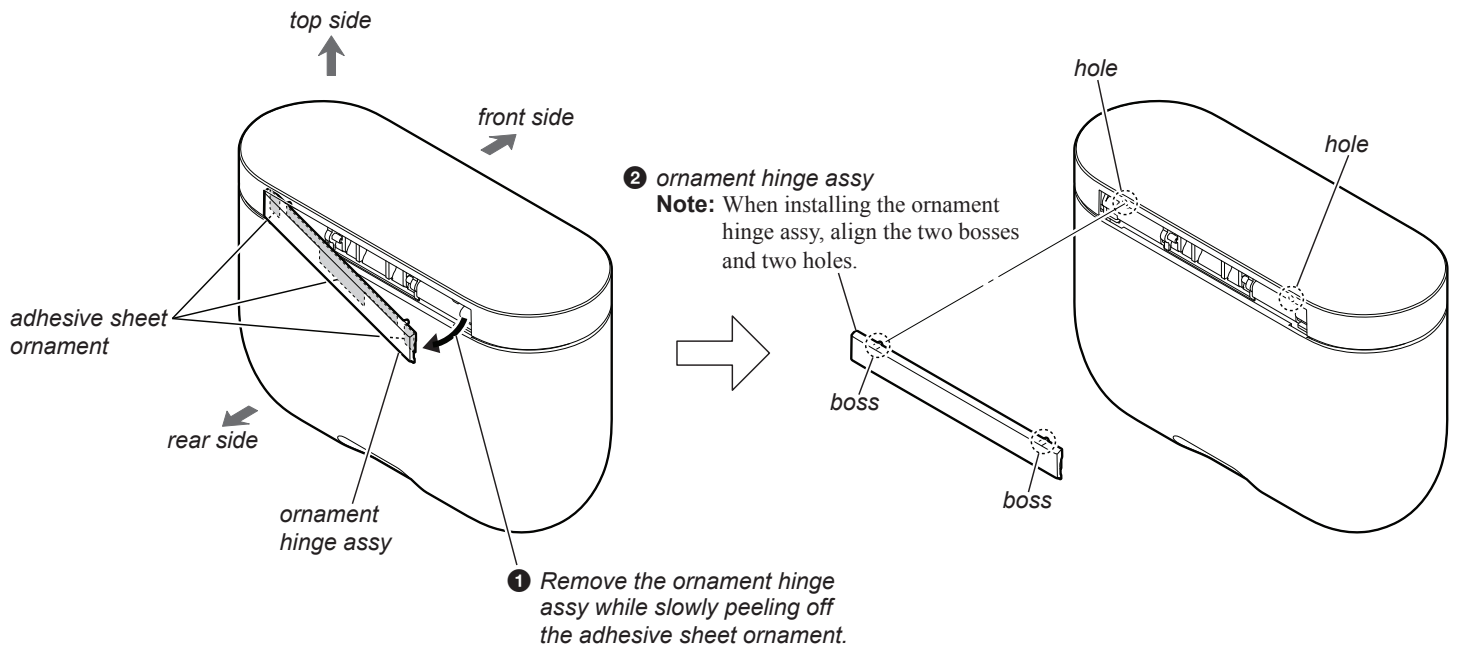

## 2-3. CASE INNER BLOCK

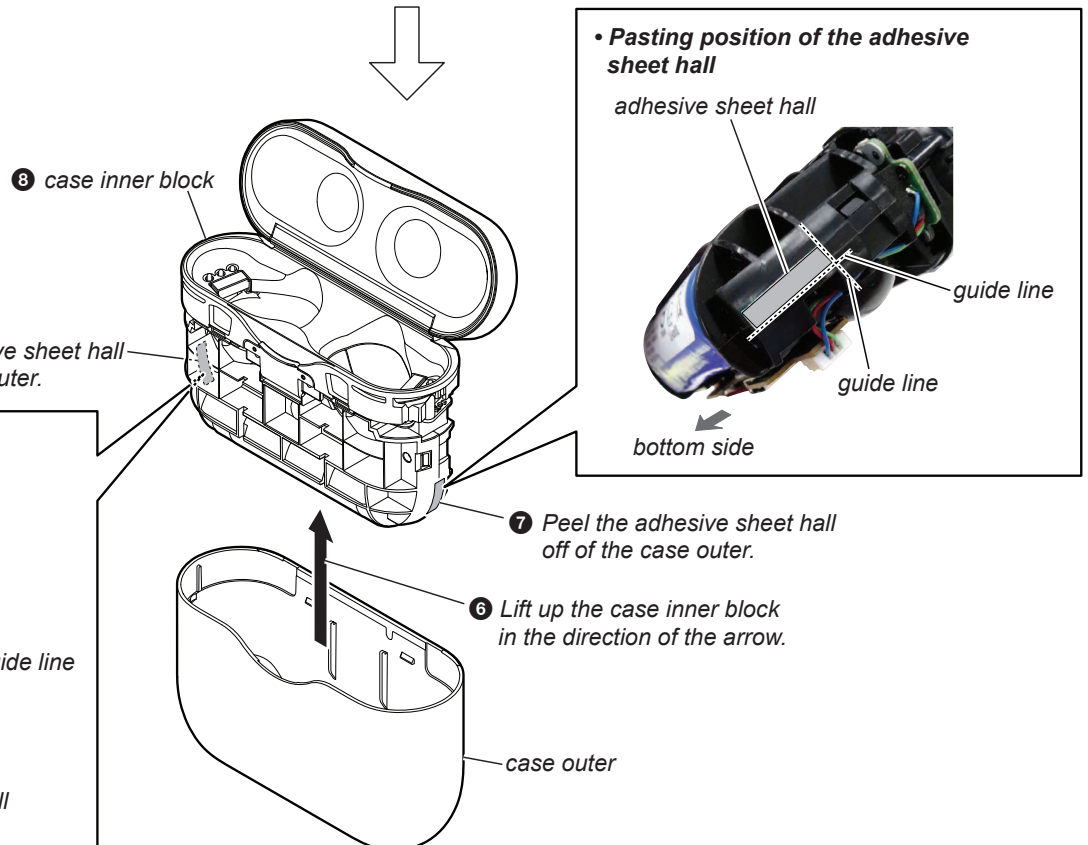
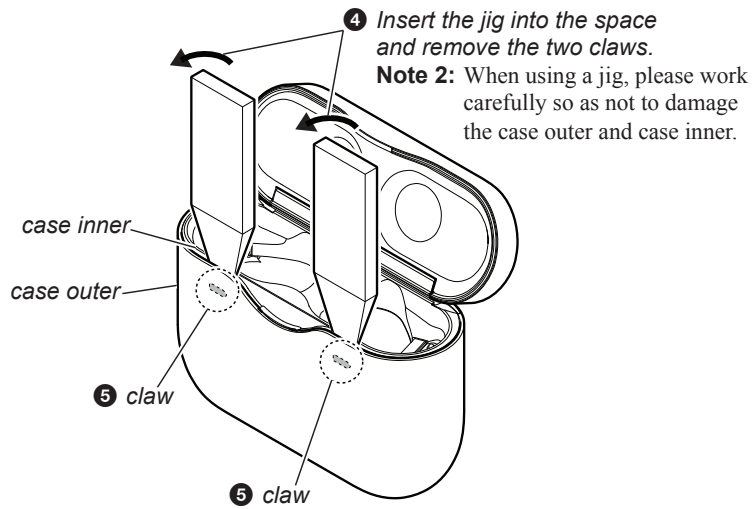
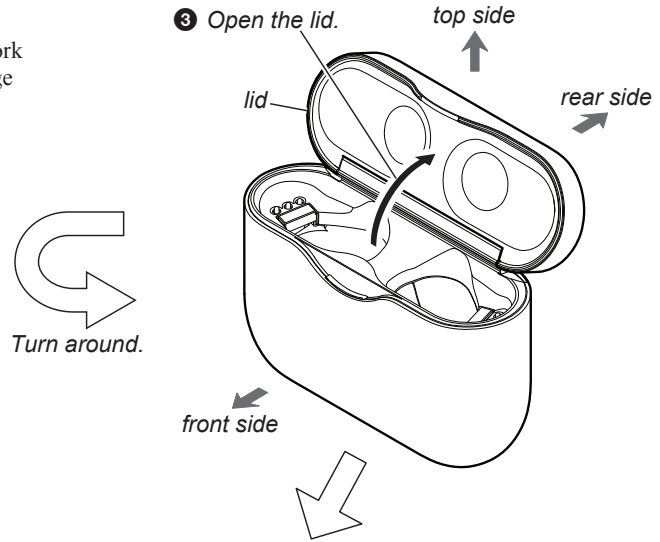
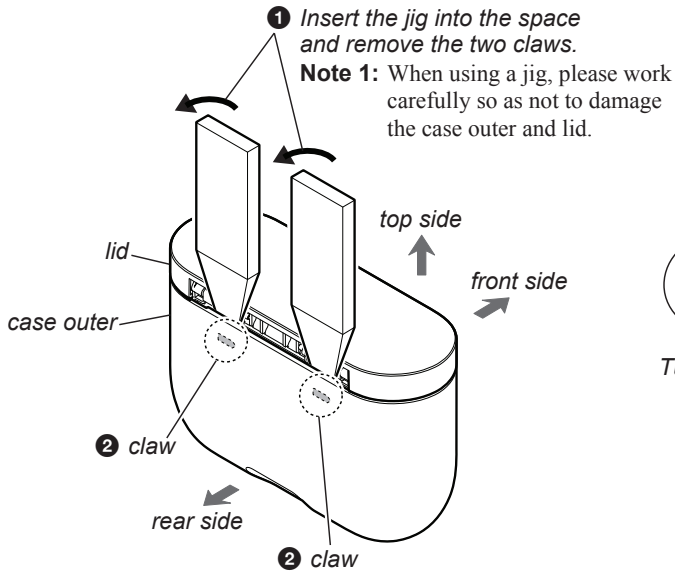

## 2-4. INDICATOR LED

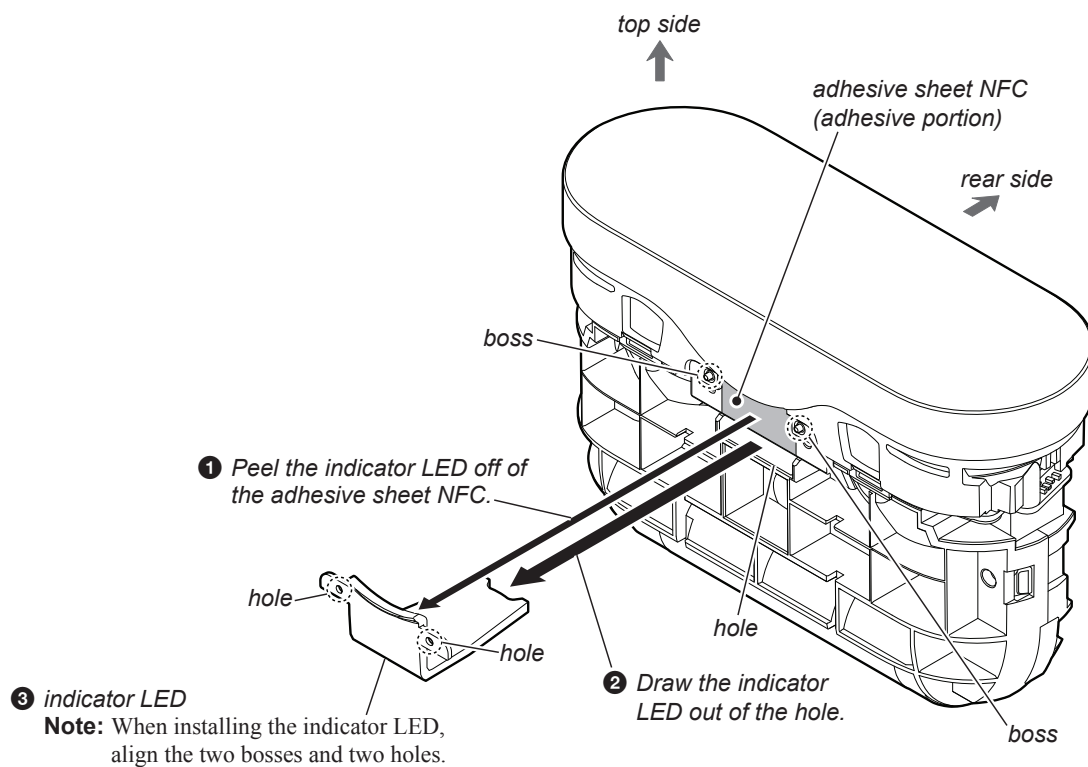

## 2-5. CASE NFC BOARD

